

The circuit shown in Figure 1 may be used to extend the line length over which the MT8972 can operate. The configuration of the circuit is the same for both 80 kbps and 160 kbps. The component values for each baud rate are listed in Table 1. Operation has been achieved with up to 40dB of line attenuation (measured at 60 kHz for 80 kbps and 120 kHz for 160 kbps). The transmission performance of the loop extender circuit for a bit error rate of 10^{-6} is summarized in Tables 2 and 3.

The MT8972 L_{OUT} (Pin #1) signal is pre-equalized and amplified. It is then passed through the line termination impedance (CL, RL, RLL) and through the transformer to the line. The transmitted power on the line is limited to 10 dBm/120 Ω and can be altered by varying the value of the resistor R2.

The MT8972 expects to receive a composite signal on L_{IN} (Pin #21) which should be one-half of $V_{L_{OUT}}$, plus the sum of the far-end signal, noise and echoes. The passive circuit (C2, C3, C4, R6, R7 and R8) supplies one half of the $V_{L_{OUT}}$ with the proper phase to optimize the internal pre-cancellation. The differencing circuit of OP2 forms the external hybrid.

The circuit shown in Figure 2 illustrates a typical application of the loop extender circuit. Jumpers allow the reconfiguration of the circuit from MT8972 alone to MT8972 with loop extender. This switchable configuration allows the MT8972 and loop extender circuit to operate on loops with attenuation less than 7dB.

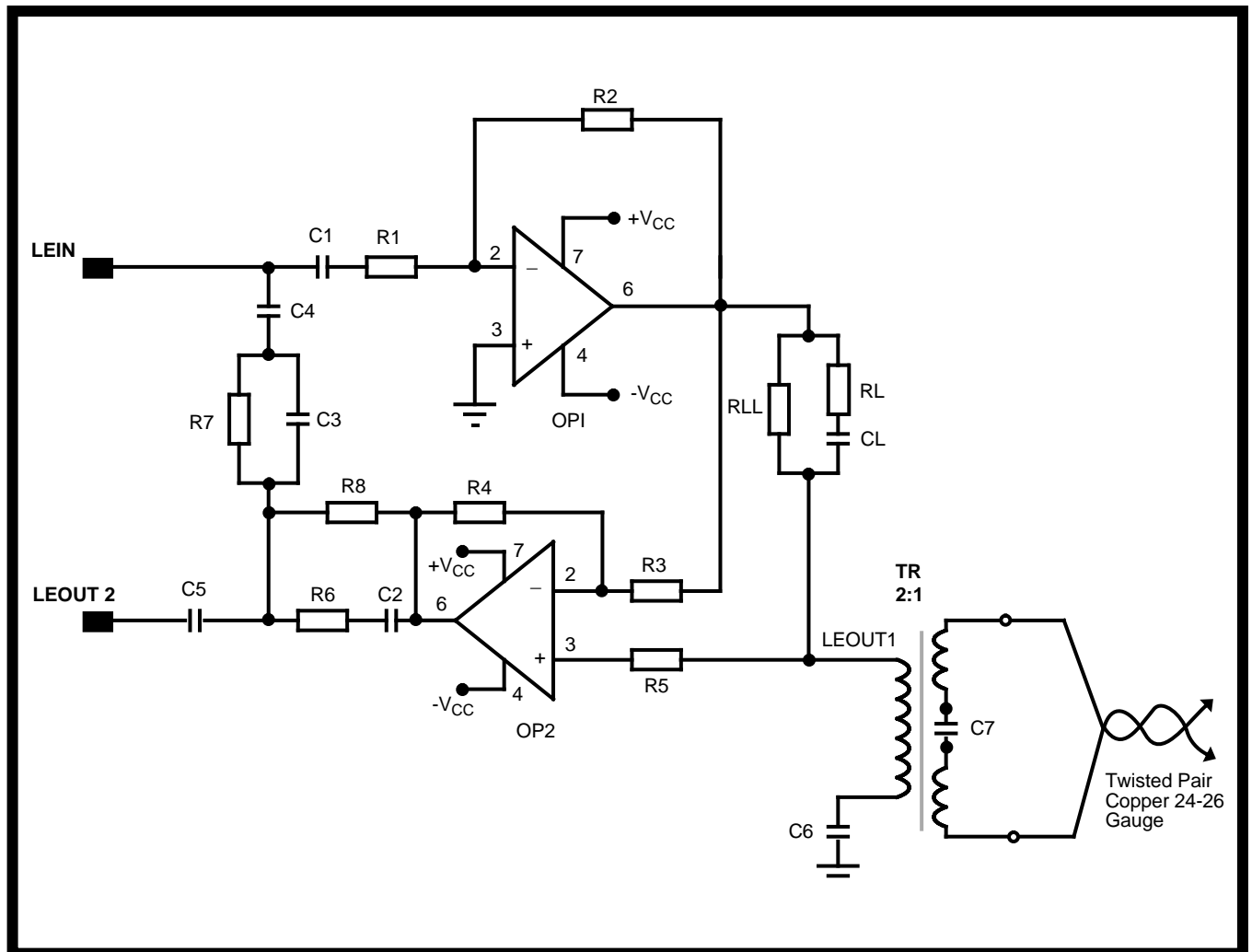

Figure 1 - Loop Extender Circuit

R1	24k	5%				
R2	75k	5%				
R3	20k	1%			80kb	160kb
R4	20k	1%	C1	560pF	5%	330pF 5%
R5	10k	10%	C2	5.6nF	5%	3.3nF 5%
R6	360Ω	2%	C3	6.2nF	5%	3.6nF 5%
R7	470Ω	2%	C4	10nF	5%	5.6nF 5%
R8	2.7k	5%	CL	12nF	5%	15nF 5%
RL	430Ω	2%	RLL	3k	5%	3.9k 5%
OP1,OP2 (Note 1)	LF411	(National Semiconductor)				
C5	47nF	10%	Note: V _{CC} = ±10 to ±15V			
C6	100nF	10%				
C7	1μF	10%				
TR	Transformer					
	1. Turns ratio 2:1 (split secondary)					
	2. Frequency response - flat passband (+/-3 dB) 10kHz to 500kHz					
	3. Primary inductance - 50 mH					
	4. DC capability - max. 100mA without transformer saturation					

Table 1. Component Values

80 kbps		
CONFIGURATION \ CABLE	24 AWG (6.9 dB/km at 60kHz)(Note 2)	26 AWG (10.0 dB/km at 60kHz)
DNIC to DNIC	0.0 to 5.2 km	0.0 to 3.4 km
DNIC with LEC* to DNIC and LEC	0.9 to 6.5 km	0.65 to 4.1 km

Table 2. Transmission Performance at 80kb (BER = 10⁻⁶)

160 kbps		
CONFIGURATION \ CABLE	24 AWG (8.0 dB/km at 120kHz)	26 AWG (11.5 dB/km at 120kHz)
DNIC to DNIC	0.0 to 4.1 km	0.0 to 3.0 km
DNIC with LEC to DNIC and LEC	0.65 to 5.1 km	0.5 to 3.6 km

Table 3. Transmission Performance at 160kb (BER = 10⁻⁶)

* LEC = Loop Extender Circuit

Note 1 : The selection criteria for operational amplifier:

- Slew rate SR ≥ 10V/μs
 - Output Voltage Swing = 20V_{pp} for R_L = 700Ω
- The specified op-amp LF411 can be replaced by LF 353 with supply voltage of ±15V ± 10%.

Note 2 : The attenuation of the cable as specified by Bell System Technical Reference PUB 62411.

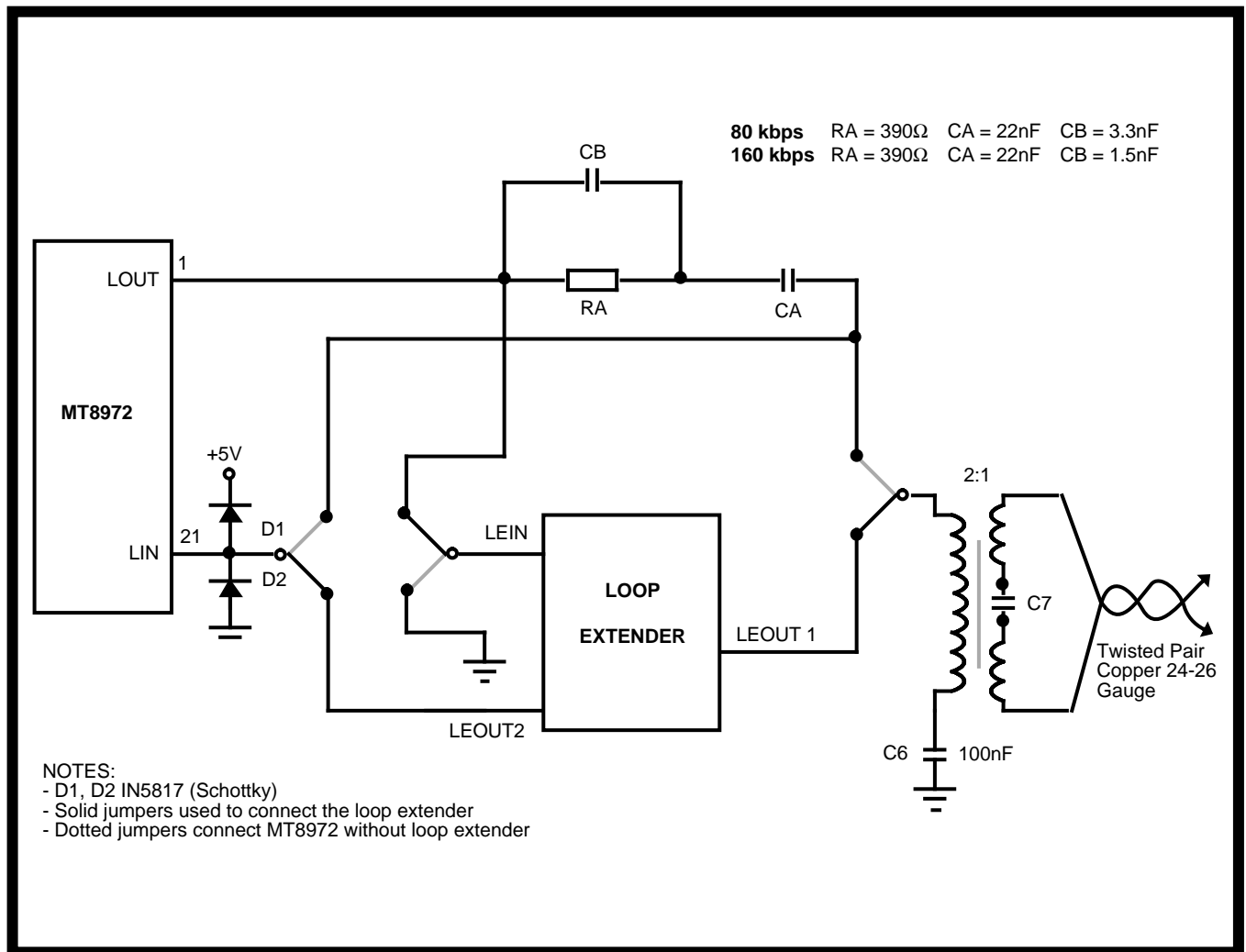

Figure 2 - Typical Application of the Loop Extender

Notes: